



A TAB Company

## STORAGE SYSTEMS

# AMES Kompress 11 Powered System

### Instant Access

When an Kompress mobile system needs to move effortlessly, Kompress 11 Powered System is the answer. One touch of the directional control button opens the aisle automatically.

### Superior Filing Density

Kompress 11 is ideal for environments where large amounts of material are stored, heavy materials are involved, and user access is frequent. The controller is designed for intuitive user operation. AMES' electrical systems can maneuver carriages up to 40 feet long\* and store up to 40,000 pounds of material.

### Safety Advantages

Safety is engineered into this system. Safety sweeps stop carriage movement when an object is encountered. The sweep is located at foot level and extends the full length of the carriages.

Kompress 11 is an ideal solution for large, high-access storage environments, and can accommodate even the heaviest of media.



### Benefits

- ✓ *Ideal for large storage systems with high access and retrieval of heavy items*
- ✓ *Capacitive directional touch control, no moving parts to wear out. One touch gives you instant access to system contents.*
- ✓ *Uniform movement protects stored material, with gradual acceleration to protect files*
- ✓ *Ideal for storing large amounts of heavy material*
- ✓ *Built-in safety features for intuitive user operation*

\*Longer carriages are available. Please contact us for a quote

# STORAGE SYSTEMS

## Built-In Safety Features

Emergency stop can cease movement from any location within the unit. If any wire becomes disconnected or any component within the safety system fails, power to all motors is immediately interrupted. Kompress 11's battery override system allows carriages to be moved individually in the event of a power failure.

The anti-tip system ensures shelving stability and is added based on height to width ratio.

Seismic bracing is available and designed to meet or exceed local, state and national codes for earthquake safety.

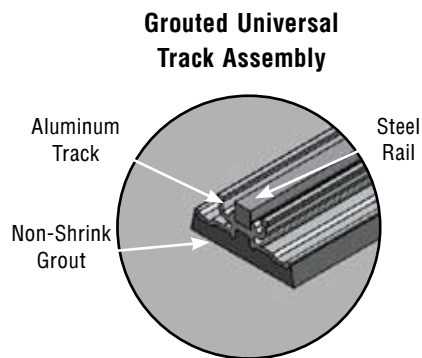

## SPECIFICATIONS

### Dimensions

Height, width and length can be designed to meet client requirements. Kompress 11 deck and carriages add 7¼" height to the overall shelving height. The overhead raceway adds 2¼" to the overall system height.

### Carriages

Kompress 11 carriages are fully welded to allow carriages to bear 1,000 pounds per linear foot. The double-flanged wheel design eliminates carriage de-railing and ensures easier guidance with no adjustment along the track. Sealed, permanently lubricated bearings provide smooth carriage movement and maintain long life with minimal maintenance. Kompress 11 carriages incorporate a 1" lip for shelving uprights & bases.

## Deck

Supported by steel channels and anchored into the sub-floor, the deck is constructed of industrial grade particleboard for uniform thickness and strength. Ramp access makes the system ADA compliant.

## Track & Flooring

- AMES' aluminum and steel wide base track is the most stable in the industry
- Supported by non-shrink grout, the aluminum track will not rust or corrode
- Track is laser leveled to 1/16" ensuring that no unwanted carriage movement will occur
- Tongue and groove rail construction ensures smooth carriage movement
- AMES certified installers accurately space the track and rail, preventing wheel, carriage and rail wear over time
- Rails can be set in concrete or in an above floor deck creating a flush walking surface
- Low profile ramp and deck access ensure easy entry and movement of wheelchairs and carts

## Simple and Unobtrusive Safety

- Obstacles are never too small or too light for the system to detect with infrared safety sweeps
- Kompress 11 controller indicates location of aisle with obstructions
- Safety system only activates on closing aisles
- Optional aisle entry sensors available

## About AMES

As a recognized leader in the records and information management industry, we develop custom solutions that enable our customers to control, store and access critical information. We offer top quality filing systems, media storage equipment and specialists that solve complex records and information management challenges. With years of experience, we serve clients in a variety of industries including legal, finance, healthcare, insurance, manufacturing, education and government.



Contact one of our representatives today

AMES • 800-343-2040 • [www.amescolorfile.com](http://www.amescolorfile.com)