



A TAB Company

# STORAGE SYSTEMS

## AMES Kompress 9 & 10 Mobile Systems

### High-Density Mobile Storage

Whether you are storing files, supplies, electronic media, or reference materials, the Kompress 9 and 10 mobile systems are ideal for any environment where space is at a premium. Kompress systems can be installed on top of an existing floor, or they can be integrated into the floor in renovation or new construction projects.

### Visually Pleasing while Saving Space

AMES Kompress mobile systems offer a complete spectrum of design possibilities, with color and texture choices to create visual harmony in any environment. End panels are available in painted steel, laminated with either self-edge, t-edge radius-edge, or custom-edge treatments. Double-faced shelving is arranged in a "T" intersection to the wall, allowing you to create aisles only when and where you need them, eliminating the need for fixed aisles.

### Configurable as Your Needs Change

Available in manual and mechanical-assist options, this sturdy system is designed for life and can be configured to your exact specifications.

Kompress 9 or 10 are ideal solutions for filing environments where high capacity, low access, and secure storage are required.

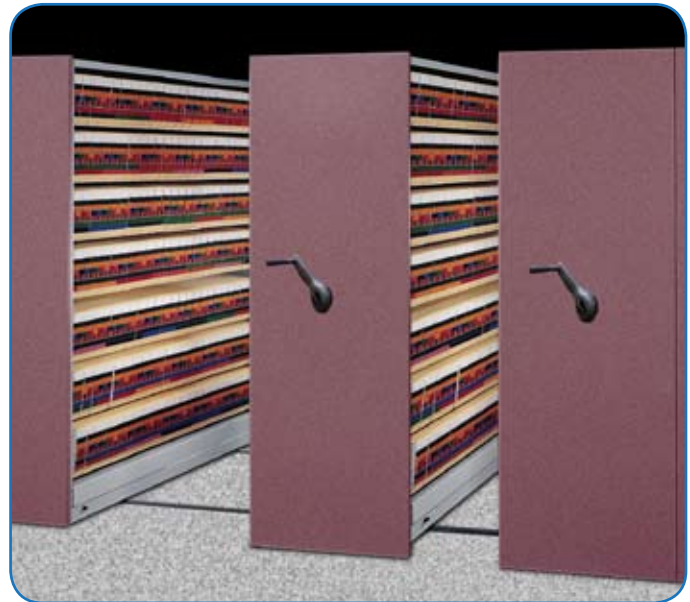

### Benefits

- ✔ *Industry leading design and high-quality materials ensure system lasts for life*
- ✔ *Built-in safety function complies with occupational safety and health regulations*
- ✔ *Configurable to your specifications and adaptable as your office environment changes (with doors and ganglocks)*
- ✔ *Lockable, secure storage helps you meet privacy legislation requirements*
- ✔ *Double your storage capacity*
- ✔ *High-density, multimedia storage in one area*

# STORAGE SYSTEMS

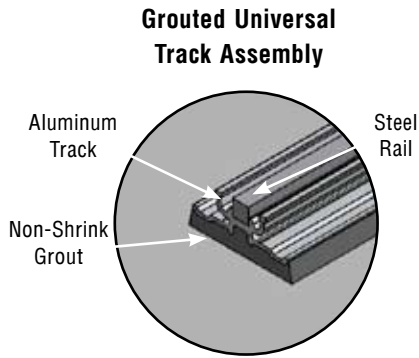

## SPECIFICATIONS

### Unit Dimensions

Height, width and depth are designed to client specifications. Kompres deck and carriages add 7¼" height to the overall storage system.

### Carriages

The double-flanged wheel design eliminates carriage de-railing and ensures easier guidance with no adjustment along the track. Sealed, permanently lubricated bearings provide smooth carriage movement and maintain long life with minimal maintenance. The carriage incorporates a 1" lip for shelving uprights and bases.

### Track and Rail

Kompres deck, track and rail set the industry standard for strength and durability. AMES certified installers laser level the system to 1/16" and secure and support the track and rail with permanent, non-shrink grout. Additionally, AMES certified installers use factory produced track spacers to evenly and accurately space track and rail, preventing wheel, carriage and rail wear over time.

### Deck

Supported by steel channels and anchored into the sub-floor, the Kompres deck provides a flush walking surface free of tripping hazards. The decks are constructed of industrial grade particleboard for uniform thickness and strength. Ramp access makes the system ADA compliant.

### Shelving

Use your existing shelving or select from one of the many AMES shelving or cabinet options. Shelving is secured to the carriages with vibration-resistant fasteners.

## OPERATION

### Manual

Manually operated storage systems are recommended for small offices where weight loads and retrieval rates are minimal. You simply move the carriage handle in the direction you want the system to move.

### Mechanical-Assist

In larger settings, where carriages are longer and weight loads are greater, the mechanical-assist Kompres system is ideal. The system's gears do most of the work; you simply rotate the carriage handle and the system does the rest.

Kompres 9 versatile mechanical carriages can maneuver up to 700 pounds per linear foot, making them ideal for light media such as letter and legal-size files. Kompres 10 heavy duty mechanical carriages can bear up to 1,000 pounds per linear foot, perfect for heavy media.

### Electrical

When a Kompres system needs to move effortlessly, Kompres 11 Powered System is the answer. One touch of the directional control button opens the aisle automatically. Kompres 11 is ideal for environments where large amounts of material are stored, heavy materials are involved, and user access is frequent. The controller is designed for intuitive user operation. And, safety is engineered into this system. Safety sweeps stop carriage movement when an object is encountered. The sweep is located at foot level and extends the full length of the carriages. The entire Kompres 11 system is UL listed.

### About AMES

As a recognized leader in the records and information management industry, we develop custom solutions that enable our customers to control, store and access critical information. We offer top quality filing systems, media storage equipment and specialists that solve complex records and information management challenges. With years of experience, we serve clients in a variety of industries including legal, finance, healthcare, insurance, manufacturing, education and government.

Contact one of our representatives today!

